

HAWORTH

# Aloha Active



# Especificacions Generals

Dissenyadors	Haworth Design Studio
Definició producte	<p>Cadira operativa giratoria amb elevació de gas.. Respatller en malla dins un marc perimetral de polipropilè. Seient fabricat amb escumes lliures de CKW entapissada en tèxtil transpirable i rentable permeten la dissipació de la calor i humutat i dissenyat amb vores arrodonides.</p> <p>Mecanisme sincronitzat autopesat amb mecanisme TTRASLA, regulació de la profunditat del seient.. Tots els mecanismes d'ajust son manejables en posició asseguda. Braços 4d, regulables en profunditat, alçada, amplada i gir de poliamida. Base de 5 radis d'alumini amb rodes amb protectors per evitar el desgast</p>
Sostenibilitat	Refer to the Product Environmental Data sheet (PED) for recycled content and certifications. For more information read more in the <a href="#">PEDS</a> .
Certificacions	GS safety EN 1335 for Aloha Active AX, GreenGuard, GreenGuard Gold
Pes	Amb braços 15 kg
Mides packaging	70x73x107 sense reposacaps 70x73x132 amb reposacaps

## Característiques – Aloha Active AX

Respatller en malla cosit i grapat, sense utilització de coles sobre un marc perimetral de polipropilè

Seient entapissat amb escuma confort elaborades sense CKW ni gasos nocius. Consistent que en pressionar no toca el pla

Regulació profunditat del seient 70mm

Regulació en alçada de 160mm amb elevació de gas

Bloqueig del respatller en 55 posicions

Base giratoria en alumini de 5 radis

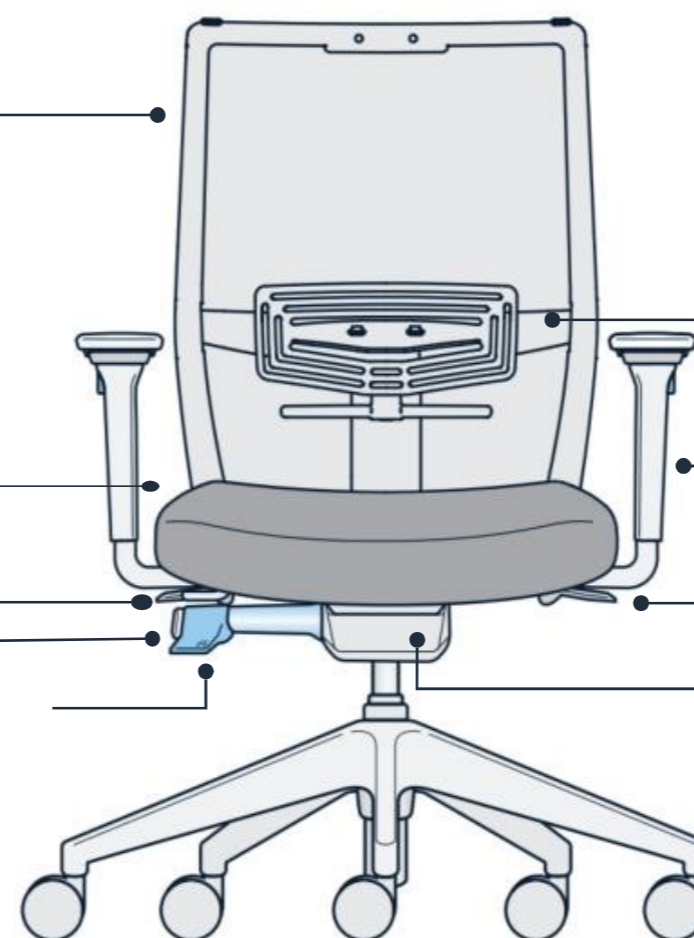

Suport lumbar regulable en alçada 770mm

Braços 4D de polipropilè d'alta resistència. Braços desmuntables

Regulació de l'amplada dels braços

Mecanisme automàtic activat en funció del pes del usuari que regula la resistència del respatller entre 40 i 1140KG

Rodes autofrenables dures, toves o amb capacitat de dissipació de la càrrega electroestàtica. Possibilitat de canvi

HAWORTH

# Braços

## Braços 4D

Permet al usuari ajustar l'alçada, l'amplada, la profunditat i el gir.

Permet al usuari ajustar la distància entre els reposabraços

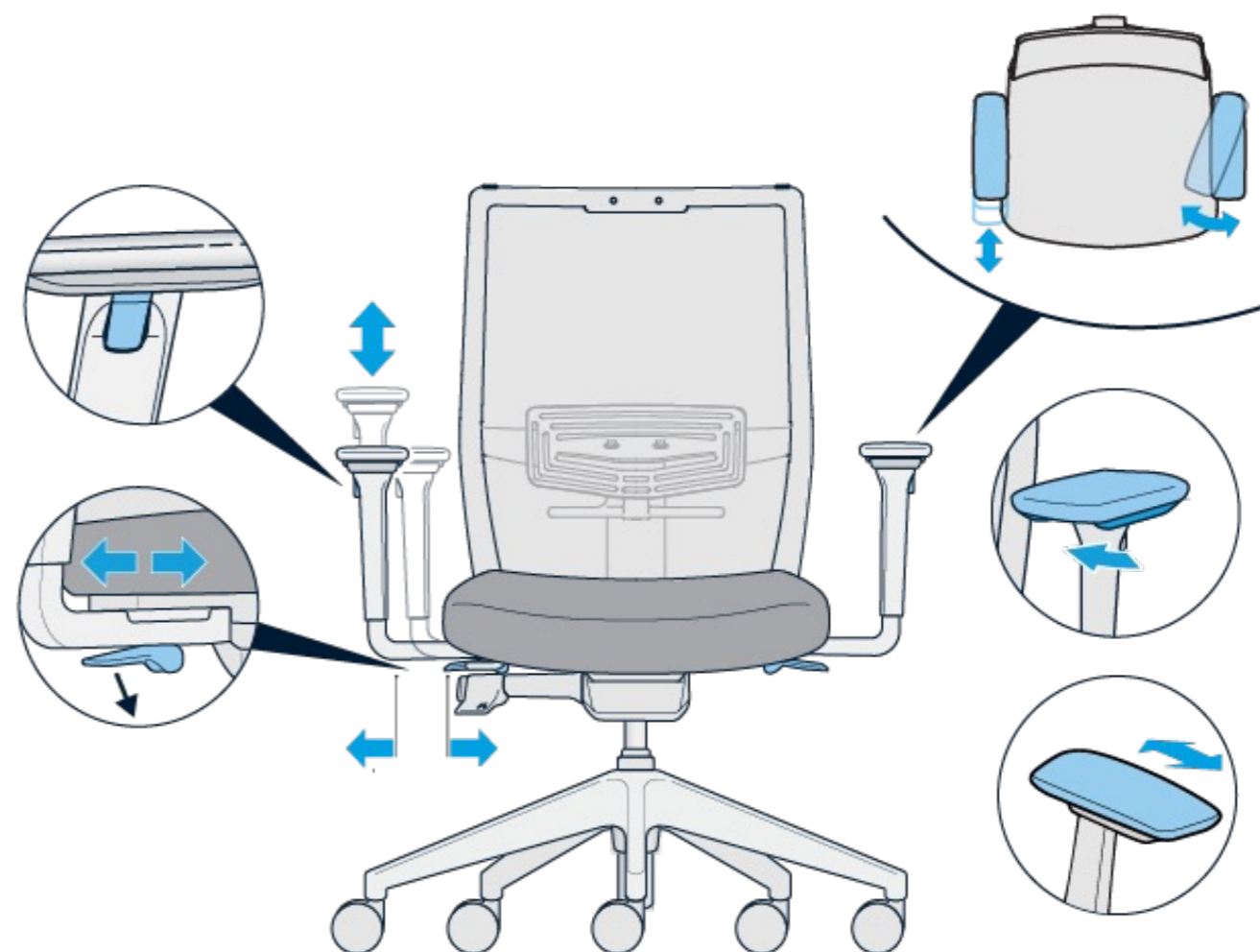



HAWORTH

Aloha Active - Fitxa tècnica

# Mides

## Dimensions

1	AAlçada	955-1115 mm
2	PProfunditat	555 mm
3	Aamplada	705 mm
4	Aalçada seient	390-550 mm
5	Aamplada seient	492 mm
6	PProfunditat seient	392 mm
7	Aalçada braç	200-310 mm
8	Aalçada Respatller	559 mm

## Options

EEscumes	lignifuga
Regulació Lumbar	Si
PPosició AAstronauta	No
tipus de Braç	4D
l'impacte mecànic	No
PPERcha	No
Reposacaps	Si
Rodes	Dures, toves, antiestàtiques

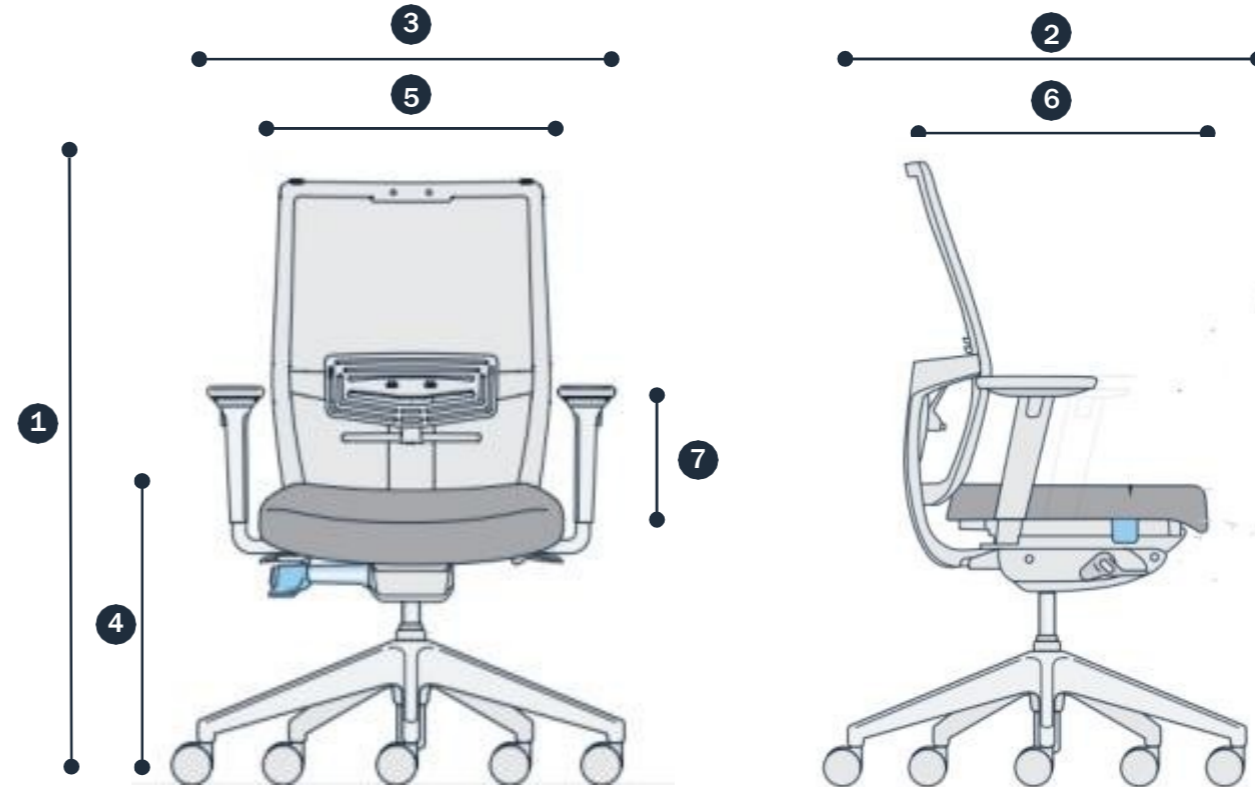

Aloha Active  
AX

## CERTIFICACIONS

- 1) Aloha Active AX, certified EN1335 type AX, available under the code SECPA

# EN 1335 Guía de tipos de productos

## Aloha Active AX

La norma EN 1335 describe cuatro tipos de sillas de trabajo de oficina que pueden obtener la certificación GS. El distintivo GS es un sello fiable de seguridad requerido en muchos proyectos. El proceso de certificación es realizado por un certificador externo e independiente. Esta guía te ayudará a comprender las diferencias entre los tipos de productos certificados GS. Toda la información relacionada con los productos puede encontrarse en The Library.

### ¿Cómo compararlas?

#### Regulación de altura del asiento

- min. 160 mm ajuste\*
- min. 130 mm ajuste
- min. 100 mm ajuste
- min. 80 mm ajuste

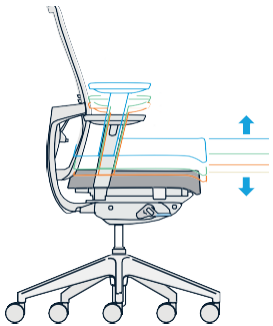

#### Regulación de la profundidad de asiento

- min. 70 mm ajuste\*
- min. 70 mm ajuste
- min. 50 mm ajuste
- -

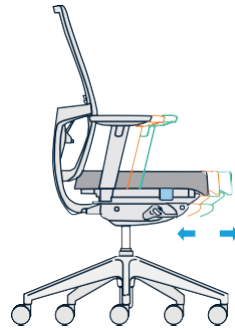

#### Soporte lumbar

- min. 70 mm ajuste\*
- min. 70 mm ajuste
- min. 50 mm ajuste
- -

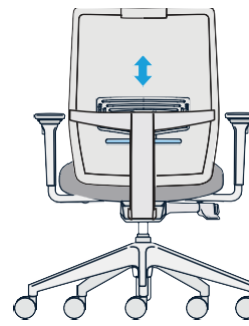

#### Altura del reposabrazos

- min. 100 mm ajuste\*
- min. 100 mm ajuste
- min. 50 mm ajuste
- -



#### Distancia entre brazos

- min. 400-520mm
- min. 480 mm ajuste
- min. 460 mm ajuste
- min. 460 mm ajuste

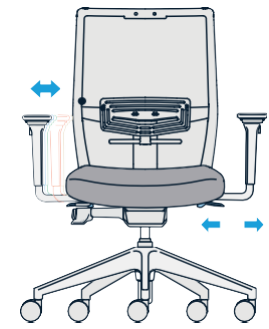

### Características y descripción por tipo de sello GS

- Tipo AX - silla de trabajo de oficina especial con la gama extra de ajustes Tipo A
- Tipo A - silla de trabajo de oficina con una amplia gama de ajustes
- Tipo B - silla de trabajo de oficina con una gama estándar de ajustes
- Tipo C - silla de trabajo de oficina con ajustes limitados

\* Disponible en el portfolio de producto Haworth. Para obtener más información, ponte en contacto con tu representante de ventas de Haworth. Dimensiones exactas disponibles a solicitud.



# Zertifikat

# Certificate



**Zertifikat Nr. Certificate No.**  
S 60162974

**Blatt Sheet**  
0001

**Gültig ab**  
28.04.2022

**Valid from**  
(day/mo/yr)

**Ihr Zeichen Client Reference**

**Unser Zeichen Our Reference**  
0010-R.S.-DE22BYTB 002

**Längstens gültig bis**  
27.04.2027

**Latest expiration date**  
(day/mo/yr)

**Genehmigungsinhaber License Holder**

Haworth GmbH  
Am Deisterbahnhof 6  
31848 Bad Münder am Deister  
Deutschland

**Fertigungsstätte Manufacturing Plant**

HAWORTH Portugal S.A.  
Estrada Consiglieri Pedroso 68  
2745-552 Queluz de Baixo  
Portugal

**Prüfzeichen Test Mark**



www.tuv.com  
ID 1111252905

**Geprüft nach Tested acc. to**

DIN EN 1335-1/07.20  
DIN EN 1335-2/04.19

**Zertifiziertes Produkt (Geräteidentifikation)  
Certified Product (Product Identification)**

**Lizenzentgelte - Einheit  
License Fee - Unit**

Bürostuhl /Office Chair

Office Work Chair "Aloha AX"

Seat height adjustable with KGS, type KGH, class 4. Synchronous mechanism lockable in 5 positions. Seat support made of plywood upholstered and covered with fabric. Backrest beam made of steel. Backrest frame made of plastic, covered with mesh. Height adjustable lumbar support made of plastic. 4D plastic armrests adjustable in height, depth and clear width as well as rotatable, attached to seat support. Aluminum base. Load-dependent braked double castors Ø 60 mm, type H or W.

Dem Zertifikat liegt unsere Prüf- und Zertifizierungsordnung zugrunde. Die Anforderungen nach § 20 des Produktsicherheitsgesetzes sind erfüllt.

*This certificate is based on our Testing and Certification Regulation. The provisions of §20 Product Safety Act are complied with.*

**TÜV Rheinland LGA Products GmbH, Tillystraße 2, 90431 Nürnberg**

http://www.tuv.com/safety E-mail: markcheck@tuv.com  
Fax: +49 221 806-3935

Übersetzung/Translation

**Ausstellungsdatum Date of Issue : 28.04.2022 (day/mo/yr)**

**Zertifizierungsstelle**

**C. Prosch**



# Aloha Active

## Seating

The Intuitive Seating Experience. The affordable task-chair hero in the workplace. Aloha makes task-seating more instinctive and fit-for-purpose. Aloha Active provides well-considered design and a revolutionary weight-activated mechanism to maximise your seating experience without compromise of quality and comfort.



Aloha Active is manufactured in a zero landfill, ISO 9001 and ISO 14001 certified facility in Portugal. This product can be easily disassembled at the end of its useful life. This product is designed to endure and is made of long-lasting, high quality materials. It has replaceable wearing parts for easy disassembly. When a product reaches the end of its useful life, customers and partners are encouraged to avoid landfilling and instead pursue second life options.

Material	Material Weight	
Plastic	7,5 kg	(49%)
Steel	6,7 kg	(44%)
Foam	0,8 kg	(5%)
Fabric	0,3 kg	(2%)
<b>Total</b>	<b>15,2 kg</b>	<b>(100%)</b>

### Recycled Content

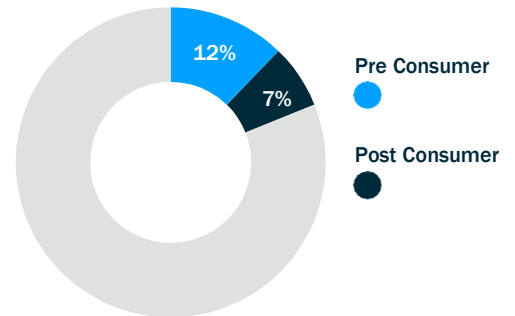

### Recyclability

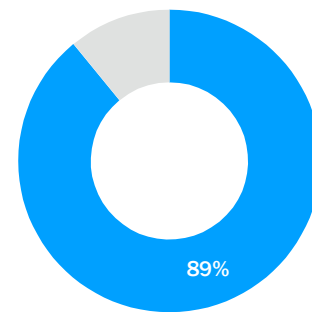

We believe that our products should be safe for humans and the environment and work diligently to identify and eliminate chemicals of concern in the materials we source. We consider applicable legal requirements (e.g. REACH, RoHS), sustainable product certifications, and our own standards as part of our sustainability strategy.

#### Aloha Active material inventory:

- No Polyvinyl Chloride (PVC).
- No Persistent Organic Pollutants (POP).
- No heavy metals (hexavalent chrome, lead, mercury).
- Chlorofluorocarbons (CFC) not used as blowing agents for foam.
- Metal parts are powder coated.
- Sustainable fabrics available (e.g., EU Ecolabel, Oeko Tex Standard 100).

Please note that calculations of recycled content are based on the displayed product configuration. Data is provided by suppliers (preferably), industry averages or other broadly based information. Our purpose is to provide the most accurate recycled content calculations possible but variability in market conditions or manufacturing processes may result in higher or lower content than indicated. Depending on the available waste management infrastructures, effective recyclability can be higher.

**Certifications**



Indoor Advantage Gold certified  
 Certification # SCS-IAQ-09627



Greenguard Gold certified  
 Certification # 250182-420

**Life Cycle Assessment (LCA)**

Haworth is committed to better understanding and reducing the environmental impacts of our products and operations.

Life Cycle Assessments (LCAs) are tools which allow us to evaluate potential environmental impacts of our products from cradle-to-grave including raw material extraction, pre-processing, production, product distribution, use and maintenance, and end-of-life management.

Results of LCA studies provide value in the identification of cost savings, improvement of design and material evaluation, advancement of procurement and transportation decision making, new product development criteria, as well as ultimately reducing Haworth's impact on the environment through continuous improvement efforts.

**Potential Sustainable Building Contributions**

Haworth products can contribute toward achieving sustainable building credits. Two of the most commonly used standards in the commercial furnishings industry are referenced here:

**Leadership in Energy & Environmental Design (LEED®) v4:**

**EQ Credit: Low-Emitting Materials**

Major products are GREENGUARD GOLD or Indoor Advantage Gold certified.

**MR Credit: Building Product Disclosure and Optimization**

**Material Ingredients: Option 1**

Material ingredient assessment per European LEVEL certification or manufacturer inventory for select products.

**Environmental Product Declarations: Option 1**

Internally reviewed product-specific Type III EPDs are available for select high-volume product lines.

**Sourcing of Raw Materials**

Recycled Content: Recycled materials disclosed in Material Section on p.1.

For potential contribution to additional ergonomic and design features, please reach out to your local Haworth representative.

**WELL Building Standard® v2:**

**Material Concept: X08 Hazardous Material Reduction**

EU Ecolabel or OekoTex Standard 100 certified textiles available. Products screened against RoHS restrictions.

**Material Concept: X10 Volatile Compound Reduction**

Part 1: Furnishings free of halogenated flame retardants.  
 Part 2: Products screened for presence of restricted phthalates.  
 Part 3: Major products are GREENGUARD GOLD or Indoor Advantage Gold certified.

**Material Concept: X11 Long-Term Emission Control**

Part 1: Major products are GREENGUARD GOLD or Indoor Advantage Gold certified.

**Material Concept: X14 Material Transparency**

Material ingredient assessment per European LEVEL certification or manufacturer inventory for select products.

**Movement Concepts: V02 Ergonomic Workstation Design and V07 Active Furnishings**

V02 Part 1: Height & angle adjustable computer monitor arms.  
 V02 Part 2, V07 Part 1: Height adjustable desks and tables.  
 V02 Part 3: Fully adjustable task seating products.

# CERTIFICATE OF COMPLIANCE



## Haworth Europe Aloha Active

250182-410

Certificate Number

20 Oct 2021 - 22 Mar 2025

Certificate Period

Certified

Status

UL 2818 - 2022 Standard for Chemical Emissions for Building Materials, Finishes and Furnishings

Commercial furniture and furnishings are tested in accordance with ANSI/BIFMA M7.1-2011(R2016) and determined to comply with ANSI/BIFMA X7.1-2011(R2016) and ANSI/BIFMA e3-2019 Credit 7.6.1. Seating products are modeled in the seating environment with a ventilation rate of 24.8 m<sup>3</sup>/hour.

Products tested in accordance with UL 2821 test method to show compliance to emission limits in UL 2818, Section 7.1.



UL investigated representative samples of the identified Product(s) to the identified Standard(s) or other requirements in accordance with the agreements and any applicable program service terms in place between UL and the Certificate Holder (collectively "Agreement"). The Certificate Holder is authorized to use the UL Mark for the identified Product(s) manufactured at the production site(s) covered by the UL Test Report, in accordance with the terms of the Agreement. This Certificate is valid for the identified dates unless there is non-compliance with the Agreement.



## GREENGUARD Certification Criteria for Mattresses, Bedding, Component Materials and Seating Units

Criteria	CAS Number	Maximum Allowable Predicted Concentration	Units
TVOC <sup>(A)</sup>	-	0.25	mg/m <sup>3</sup>
Formaldehyde	50-00-0	30.7 (25 ppb)	µg/m <sup>3</sup>
Total Aldehydes <sup>(B)</sup>	-	0.50	ppm
4-Phenylcyclohexene <sup>(C)</sup>	4994-16-5	3.25	µg/m <sup>3</sup>
Individual VOCs <sup>(D)</sup>	-	1/10th TLV	-

- (A) Defined to be the total response of measured VOCs falling within the C<sub>6</sub> – C<sub>16</sub> range, with responses calibrated to a toluene surrogate.
- (B) The sum of all measured normal aldehydes from formaldehyde through nonanal, plus benzaldehyde, individually calibrated to a compound specific standard. Heptanal through nonanal are measured via TD/GC/MS analysis and the remaining aldehydes are measured using HPLC/UV analysis.
- (C) Applicable to flooring and furniture, including component materials.
- (D) Allowable levels for chemicals not listed are derived from 1/10th of the Threshold Limit Value (TLV) industrial work place standard (Reference: American Conference of Government Industrial Hygienists, 6500 Glenway, Building D-7, and Cincinnati, OH 45211-4438).



UL investigated representative samples of the identified Product(s) to the identified Standard(s) or other requirements in accordance with the agreements and any applicable program service terms in place between UL and the Certificate Holder (collectively "Agreement"). The Certificate Holder is authorized to use the UL Mark for the identified Product(s) manufactured at the production site(s) covered by the UL Test Report, in accordance with the terms of the Agreement. This Certificate is valid for the identified dates unless there is non-compliance with the Agreement.

SCS Global Services does hereby certify that an independent assessment has been conducted on behalf of:

# Haworth Europe

Am Deisterbahnhof 6, 31848 Bad Muender, Germany

For the following product(s):

## Seating:

Aloha Active\*, Aloha AX, Bowi\*, Cabana†, Cardigan Lounge, Comforto 59\*, Fern, Intermezzo, Lively\*, Maari\*, Nia, Poppy\*, Riverbend, Soji, Very, Zody, Zody II, Zody LX

\* Products have various configurations

□ Does not include models with privacy screens



The product(s) meet(s) all of the necessary qualifications to be certified for the following claim(s):

## Indoor Advantage™ Gold

Indoor Air quality Certified to SCS-EC10.3-2014 v4.1

Conforms to the ANSI/BIFMA Furniture Emissions Standard (M7.1/X7.1-2011 R2021 and ANSI/BIFMA e.3-2019 (Credits 7.6.1, 7.6.2, 7.6.3) for seating parameters.<sup>1</sup> Also, conforms to the CDPH/EHLB Standard Method (CA 01350) v1.2-2017 for seating<sup>1</sup> and school classroom parameters<sup>1,2</sup>

<sup>1</sup> Modeled as Office Seating

<sup>2</sup> Modeled as Pupil Seating



Registration # SCS-IAQ-09627

Valid from: December 13, 2023 to July 31, 2024



Nicole Munoz, Vice President  
2000 Powell Street, Ste. 600, Emeryville, CA 94608 USA

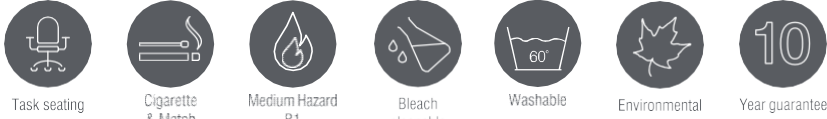

Xtreme is a modern crepe weave fabric made from 100% post-consumer recycled polyester, diverting waste from landfill and saving virgin raw materials. Its stretch properties, coupled with high flame retardancy, durability and non-pilling properties make Xtreme an ever popular fabric for task seating.



STANDARD 100  
11-62664 Shirley  
www.oeko-tex.com



Technical information

**UK**  
**Composition**  
100% post-consumer recycled polyester  
**Environment**  
Certified to the EU Ecolabel  
Certified to STANDARD 100 By OEKO-TEX®  
Certified to Indoor Advantage™ Gold  
Made from 100% recycled polyester  
Non metallic dyestuffs  
**Width**  
140 cm minimum  
**Weight**  
310 g/m<sup>2</sup> ±5% (434 g/lin.m ±5%)  
**Abrasion Resistance\***  
Heavy duty / 10 year guarantee  
Independently certified to ≥100,000 Martindale cycles

**Flammability**  
EN 1021 - 1 (cigarette)  
EN 1021 - 2 (match)  
BS 7176 Low Hazard  
BS 5852 Ignition Source 5  
BS 7176 Medium Hazard  
DIN 4102 B1  
NF D 60-013  
ONORM B 3825 & A 3800-1 (over 58 kg/m<sup>3</sup> CMHR foam)  
UNI 9175 Classe 1 IM  
BS 476 Part 7 Class 1 (Adhered)  
*Note: Flammability performance is dependent on components used. Our certificates show what substrates have been used in our tests. For composite tests customers must ensure their complete furniture meets the necessary standards.*

**Light Fastness**  
6 (ISO 105 - B02)

**Fastness to Rubbing**  
Wet: 4, Dry: 4 (ISO 105 - X12)

**Bleach Cleanable**  
ISO 105 E03 colour change 4 for dilution factor 1:4 chlorine solution

**Cleaning**  
Vacuum regularly. Wipe with a damp cloth using a proprietary upholstery shampoo/ soap. For deeper cleaning use steam, bleach, alcohol or professionally dry clean. Can be washed at 60°C. Full details can be found in our cleaning and disinfection guide.

\*Abrasion testing produces a wide variability of results even from the same test sample. The independent certificate of ≥100,000 cycles is available on our website or from our customer service team. Internally we also specify this product at >100,000 cycles which we believe is realistic for repeatability of testing. Please be aware that abrasion testing alone is not a reliable indicator of the actual wear performance of fabrics. We're so confident in the durability of our products that we provide a robust 10 year guarantee (full details available). Please note that seam performance is dependent on seam construction and needle and thread type. We recommend that appropriate sewing advice be taken. Batch to batch variations in shade may occur within commercial tolerances. We reserve the right to alter technical specifications without notice. The Unregistered Design Rights and the Copyright in all designs are the exclusive property of Camira Fabrics Limited.

**D**  
**Zusammensetzung**  
100% post-consumer recycelten Polyester  
**Umweltfreundlich**  
Nach Zertifikat EU Ecolabel  
Nach Zertifikat STANDARD 100 By OEKO-TEX®  
Nach Zertifikat Indoor Advantage™ Gold  
Hergestellt aus 100% recycelten Polyester  
Nicht schwermetallhaltige Farbstoffe  
**Breite**  
140 cm nutzbare Breite  
**Gewicht**  
310 g/m<sup>2</sup> ±5% (434 g/lf.d.m ±5%)  
**Scheuerfestigkeit\***  
Schwerer Objekteinsetz / 10 Jahre Garantie  
Extern zertifiziert mit ≥100,000 Scheuertouren Martindale

**Feuersicherung**  
EN 1021 - 1 (Zigarettentest)  
EN 1021 - 2 (Streichholztest)  
BS 7176 Low Hazard  
BS 5852 Ignition Source 5  
BS 7176 Medium Hazard  
DIN 4102 B1  
NF D 60-013  
ONORM B 3825 & A 3800-1 (mit 58 kg/m<sup>3</sup> CMHR Schaum)  
UNI 9175 Classe 1 IM  
BS 476 Part 7 Class 1 (Adhered)  
*Bemerkung: Die Schwerentflammbarkeit hängt von den verwendeten Komponenten ab. Unsere Zertifikate zeigen auf, welche Substrate bei den Tests verwendet wurden. Bei Verbundtests muss sichergestellt sein, daß das komplette Möbel den entsprechenden Standards entspricht.*

**Lichtechtheit**  
6 (ISO 105 - B02)

**Reibechtheit**  
Nass: 4, Trocken: 4 (ISO 105 - X12)

**Chlorbleiche-Beständig**  
ISO 105 E03 Farbänderung 4 bei einer 1:4 verdünnten Chlor-Lösung

**Reinigung**  
Regelmässig absaugen. Mit einem feuchten Tuch abwischen oder mit einem geeigneten Polstershampoo behandeln. Für eine Grundreinigung bitte Dampf, Chlorbleiche, Alkohol oder professionelle Trockenreinigung verwenden. Kann bei 60°C gewaschen werden. Weitere Informationen finden Sie in unserem Leitfaden zur Reinigung und Desinfektion.

\*Die Scheuerfestigkeitsprüfung ergibt selbst bei gleichen Testmustern stark abweichende Ergebnisse. Das Zertifikat eines unabhängigen Prüfinstitutes über ≥100,000 Scheuertouren erhalten Sie von unserem Vertriebsdienst oder auf unserer Webseite. Intern spezifizieren wir auch dieses Produkt mit >100,000 Scheuertouren, die in der Serienfertigung als realistisch angenommen werden. Bitte nehmen Sie zur Kenntnis, dass die Scheuerfestigkeitsprüfung allein keine Aussagekraft über die Langlebigkeit eines Bezugsstoffes hat. Wir sind von der Langlebigkeit unserer Produkte überzeugt und bieten daher 10 Jahre Garantie (Details auf Anfrage). Eine optimale Nahtausreissfestigkeit hängt von der Nahtfahne, der verwendeten Nadel und dem Näh-Garn ab. Wir empfehlen daher Näversuche durchzuführen. Handelsübliche Farbabweichungen können auftreten und berechtigen nicht zur Reklamation. Wir behalten uns die Änderung technischer Spezifikationen vor. Die registrierten und nicht registrierten Urheberrechte der Dessinierungen sind ausschliessliches Eigentum der Camira Fabrics Limited.

**F**  
**Composition**  
100% polyester recyclé post-consommation  
**Écologique**  
Avec le certificat EU Ecolabel  
Certifié à STANDARD 100 By OEKO-TEX®  
Certifié à Indoor Advantage™ Gold  
Fabriqué d'un polyester 100% recyclé  
Teintures non métalliques  
**Largeur**  
140 cm minimum  
**Poids**  
310 g/m<sup>2</sup> ±5% (434 g/m.l ±5%)  
**Résistance à l'abrasion\***  
Usage intense / garantie 10 ans.  
Certificat indépendant ≥100,000 cycles Martindale

**Flammabilité**  
EN 1021 - 1 (cigarette)  
EN 1021 - 2 (allumette)  
BS 7176 Low Hazard  
BS 5852 Ignition Source 5  
BS 7176 Medium Hazard  
DIN 4102 B1  
NF D 60-013  
ONORM B 3825 & A 3800-1 (sur 58 kg/m<sup>3</sup> CMHR mousse)  
UNI 9175 Classe 1 IM  
BS 476 Part 7 Class 1 (Adhered)  
*Notez: La performance de flammabilité dépend des composantes utilisées. Nos certificats indiquent les substrats utilisés dans nos tests. Pour les tests composites, les clients doivent s'assurer que leurs meubles complets satisfont aux normes nécessaires.*

**Solidité à la lumière**  
6 (ISO 105 - B02)

**Solidité au Frottement**  
Mouillé: 4, Sec: 4 (ISO 105 - X12)

**Nettoyage au javel**  
ISO 105 E03 changement de couleur 4 pour le facteur de dilution 1: 4 solution de chlore

**Nettoyage**  
Passez l'aspirateur régulièrement. Essayez avec un chiffon humide en utilisant un shampoing/savon pour tissus d'ameublement exclusif. Pour un nettoyage en profondeur, utilisez la vapeur, javel, alcool ou un nettoyage à sec professionnel. Peut être lavé à la machine, programme maximum 60°C. Vous trouverez tous les détails dans notre guide de nettoyage et de désinfection.

\*Les tests de résistance à l'abrasion proposent une large variété de résultat final, parfois sur le même échantillon de tissu. Le certificat indépendant de ≥100,000 cycles est disponible sur notre site internet; vous pouvez également contacter notre Service Clients. Nous validons également – en interne – à >100,000 cycles; ce qui est, d'après nous, plus réaliste dans le but d'obtenir une continuité égale des résultats de tests. Merci de noter que l'abrasion seule ne constitue pas un indicateur de confiance dans la performance du tissu à long terme. Nous avons une confiance absolue en nos produits et leur durabilité, c'est pour cela que nous vous offrons une garantie robuste de 10 ans. Veuillez noter que la performance du joint dépend de sa construction ainsi que de l'aiguille et du type de fil utilisés. Une variation de couleurs peut provenir (commercialement tolérable). Nous réservons le droit de changer les spécifications techniques sans préavis. Les Droits de Conception non-enregistrés et les droits d'auteur de tous les motifs sont la propriété exclusive de Camira Fabrics Limited.

**ES**  
**Composición**  
Polyester reciclado 100% post consumido  
**Ambiental**  
Certificado con EU Ecolabel  
Certificado de STANDARD 100 By OEKO-TEX®  
Certificado de Indoor Advantage™ Gold  
Hecho de 100% de poliéster reciclado  
Tintes no metálicos  
**Ancho**  
140 cm mínimo  
**Peso**  
310 g/m<sup>2</sup> ±5% (434 g/lin.m ±5%)  
**Resistencia a la abrasión\***  
Garantía de 10 años con uso intenso  
Independientemente del certificado de ≥100,000 Ciclos Martindale

**Inflamabilidad**  
EN 1021 - 1 (cigarillo)  
EN 1021 - 2 (cerilla)  
BS 7176 Low Hazard  
BS 5852 Ignition Source 5  
BS 7176 Medium Hazard  
DIN 4102 B1  
NF D 60-013  
ONORM B 3825 & A 3800-1 (con CMHR 58 kg/m<sup>3</sup> de espuma)  
UNI 9175 Classe 1 IM  
BS 476 Part 7 Class 1 (Adhered)  
*Nota: El rendimiento de la inflamabilidad depende de los componentes usados. Nuestros certificados muestran que substratos se han usado en nuestros tests. Para tests compuestos nuestros clientes deben asegurar si sus muebles cumplen la normativa al uso.*

**Solidez a la luz**  
6 (ISO 105 - B02)

**Solidez al rozamiento**  
Húmedo: 4, Seco: 4 (ISO 105 - X12)

**Posibilidad lavado con Lejía**  
ISO 105 E03 lavado color 4 para un factor de disolución 1:4 solución cloro

**Limpeza**  
Usó aspirador regularmente. Limpiar con un trapo usando jabón y agua o producto limpieza para tapicerías. Para una limpieza más profunda usen vapor, lejía, alcohol o limpieza en seco. Se puede lavar a 60°C. Los detalles completos se encuentran en nuestra guía de limpieza y desinfección.

\*Los Test de Abrasion producen unos resultados muy variables incluso con la misma muestra. El certificado de ≥100,000 ciclos Martindale está disponible en nuestra web o se puede pedir al Departamento Comercial. Internamente también certificamos este producto >100,000 ciclos, que pensamos que es lo más realista posible en este caso, con una repetición de resultados tan dispares. Tengan en cuenta que el Test de Abrasion solo no es un indicador fiable sobre el desgaste de un tejido. De hecho, estamos tan convencidos en la durabilidad de nuestros tejidos, que ofrecemos una garantía de 10 años (detalles completos disponibles). Tenga en cuenta que el rendimiento de la costura depende de la construcción de la costura, además de la aguja y del tipo de rosca. Le recomendamos que se aconsejen para coser la costura. Las variaciones de lote a lote en la sombra se puede producir dentro de tolerancias comerciales. Nos reservamos el derecho a efectuar modificaciones técnicas sin previo aviso. Los derechos sobre los diseños no registrados y los derechos de autor en todos los diseños son propiedad exclusiva de Camira Fabrics Limited.

Company Name: IMARC SPA  
Company Address: Via Meucci, 21 - 36028 Rossano Veneto - Vicenza, Italy  
Contact Person: Andrea Gastaldon  
E-Mail Address: andrea.gastaldon@imarc.it  
Telephone: +39 0424 031100

## Material Chemistry Disclosure & Compliance Declaration

This declaration applies to all products and parts supplied to Haworth. Please select the appropriate answer(s) by checking off the corresponding box(es) in the following sections 1 and 2. For section 2: If the question is not applicable to the products and parts you supply to Haworth, please select "not applicable". No box should be left blank.

### 1. Disclosure & Compliance with General Material Chemistry Requirements (all products)

#### (1) Article 33 of EU Regulation 1907/2006 (REACH)

Provided products, as well as any articles within these products, **DO NOT CONTAIN** any REACH SVHCs in concentrations above 1000ppm (current list, see [ECHA Candidate List](#)).

Provided products have been evaluated for the presence of REACH SVHCs and **DO CONTAIN** SVHCs in concentrations of higher than 1000ppm and are documented in the attached Excel table "Haworth Material Chemistry Compliance Annex". (*Table must be completed if this option is selected.*)

#### (2) Article 67 of EU Regulation 1907/2006 (REACH)

Provided products, as well as any articles within these products, have been evaluated for the presence of restricted substances listed in REACH Annex XVII and **DO NOT CONTAIN** any of the restricted substances within the scope of the restriction (current list, see [ECHA Restricted Substances](#)).

#### (3) EU Regulation 2019/1021 (EU POP Regulation)

Products comply with the Regulation on Persistent Organic Pollutants (POP) and **DO NOT CONTAIN** substances subject to prohibitions listed in Annex I to Regulation (EU) 2019/1021 and its amendments (for details, see [ECHA homepage](#)).

#### (4) Safety & Environmental Data Disclosure

Safety Data Sheets **ARE AVAILABLE** for the substances and/or mixtures used in the supplied products, where relevant e.g., for adhesives, plasticizers, surface finishes/powders. (*Please provide corresponding datasheets when selected.*)

Carbon footprint calculations **ARE AVAILABLE** for provided products e.g., through Life Cycle Assessments (LCA), Environmental Product Declarations (EPD) or similar environmental datasheets. (*Please provide corresponding documentation when selected.*)

### 2. Disclosure & Compliance with Specific Material Chemistry Requirements (as indicated)

#### (1) Wood-Based Materials and Products

- No Wood-based products (e.g., chipboard, blockboard, veneer panels, seat shells) **DO COMPLY** with the limit values of applicable emission classes e.g., E0, E1, CARBII/TSCA Title 6, confirmed through appropriate testing. (*Please provide laboratory/testing documentation when selected.*)
- No Wood-based products, including packaging materials, **ARE CERTIFIED** according to a recognized chain of custody certification scheme, like FSC, PEFC or SFI. (*Please provide the valid certificate when selected.*)
- No Wood-based products **DO CONTAIN** recycled content. If not compromising on material quality or health, Haworth favors high recycled content in its materials. (*Please provide details on pre- and post-consumer recycled content share (%) of products supplied to Haworth.*)
- Not known For wood-based products with recycled content: Products **DO NOT CONTAIN** any substances in given concentrations according to the EPF Standard for Delivery Conditions of Recycled Wood (see [Europanel's homepage](#) for EPF Standard).

# HAWORTH

## (2) Fabrics

No Fabrics ARE TESTED for the absence of harmful substances according to a recognized standard, like Oeko-Tex, EU Ecolabel, Cradle-2-Cradle, GECA, BlueSign or equivalent. (Please provide the valid certificate or laboratory/testing documentation.)

## (3) Foam and Padding Products

Yes Halogenated organic blowing agents (CFC, HFC, HCFC) are NOT USED in the production of foams supplied to Haworth.

Yes Aniline based amines are NOT USED in the production of foams supplied to Haworth. (Please provide the corresponding Safety Datasheet(s) for proof.)

No Foams ARE TESTED for the absence of harmful substances according to a recognized standard, like OekoTex, CertiPur or equivalent. (Please provide the valid certificate or testing documentation.)

## (4) Plastic Parts and Components

Yes Plastic with  $\geq 50$  grams in part weight ARE MARKED for recycling according to ISO 11469. When marking is not possible, please explain why:

Yes Provided plastic parts are FREE OF Polyvinylchloride (PVC).

Yes Plastic parts DO CONTAIN recycled content. If not compromising on material quality or health, Haworth favors high recycled content in its materials. (Please provide details on pre- and post-consumer recycled content share (%) of products supplied to Haworth.)

## (5) Metal Parts and Components

Yes Metal parts DO CONTAIN recycled content. If not compromising on material quality or health, Haworth favors high recycled content in its materials. (Please provide details on pre- and post-consumer recycled content share (%) of products supplied to Haworth.)

## (6) Electronic and Electrical Components

Not applicable In line with Directive 2011/65/EU (RoHS), provided product(s) DO NOT CONTAIN any of the following substances in the given concentrations or higher:

- Cadmium (Cd): 100 ppm
- Lead (Pb): 1000 ppm
- Mercury (Hg): 1000 ppm
- Hexavalent Chromium: (Cr VI) 1000 ppm
- Polybrominated Biphenyls (PBB): 1000 ppm
- Polybrominated Diphenyl Ethers (PBDE): 1000 ppm
- Bis(2-Ethylhexyl) phthalate (DEHP): 1000 ppm
- Benzyl butyl phthalate (BBP): 1000 ppm
- Dibutyl phthalate (DBP): 1000 ppm
- Diisobutyl phthalate (DIBP): 1000 ppm

If No was selected, substances and concentrations are to be documented in the attached Excel table "Haworth Material Chemistry Compliance Annex". (Table must be completed if "No" was selected.)

Haworth reserves the right to verify the production of any item or substance used in the preparation of its orders at any stage.

The supplier commits to inform Haworth promptly of any changes regarding this declaration.

Signed on Rossano Veneto, 28/11/2023 ..... (date, location)

IMARC

IMARC S.p.A.

Via Meucci, 21

36028 ROSSANO VENETO (VI)

C.F. e P.IVA 01901070241

T: 0424 031100 - Pec: imarc@legalmail.it

codice SDI T04ZHK3



.....  
Signature



DESIGN  
AWARD  
2021

**DISCIPLINE PRODUCT**  
**CATEGORY 1.11 Office**

## Nia

**agile work chair**

### DESIGN

brodbeck-koepf design  
Munich, Germany

### CLIENT / MANUFACTURER

Haworth GmbH  
Bad Münden am Deister, Germany

#### Jury

Marika Aakesson | Werner Aisslinger | Josephine Akvama Hoffmeyer | Marta Alonso Yebra | Silvana Angeletti | Keiji Ashizawa | Serdal Korkut Avci | Tomoko Azumi | Jan-Erik Baars | Ceren Bagatar | Stefan Behnisch | Michal Bonikowski | Philipp Bree | Dave Brown | Uwe Brückner | Maïke Budde | Sean Carney | Eva Castro | Annie Chang | Chi-Yi Chang | Emil Chao | Shikuan Chen | Lee Chen | Albert Chen | Patrizio Cionfoli | Paul Cohen | Sonja Cornelißen | Isabelle Dahlborg Lidström | Michele De Lucchi | Christian Doering | Bern Donadeu | Manfred Dorn | Friederike Faller | Fritz Frenkler | Claudia Friedrich | Marisa Gallén | Niklas Galler | Manuel Gattinger | Oliver Gerstheimer | Isabelle Goller | Senna Graulus | Gyeongguk Grey Choe | Matthis Hamann | Sascha Hanke | Gesa Hansen | Sam Hecht | Olivia Herms | Tom Hirt | Britta Hölscher | Daisuke Ishii | Neslihan Isik | Morten Bo Jensen | Henrik Jeppesen | Long Jiao | Ann Kalkschmidt | Karen Korellis Reuther | Henk Kosche | Michael Lanz | Kristiina Lassus | Sukwoo Lee | Lidan Liu | Sam Livingstone | Petra Lundblad | Kazushige Miyake | Nils Holger Moormann | Alexander Müller | Darragh Murphy | Achim Nagel | Stina Nilimaa Wickström | Changho Noh | Katrin Oeding | Lutzia Ortiz Miralles | Haruki Ota | Thomas Paulen | Andy Payne | Achim Pohl | Fátima Pombo | Claudia Pommer | Bruno Porto | Ana Relvão | Nina Rieke | Andreas Rotzler | Robert Sachon | Annett Schaper | Sonja Schiefer | Johanna Schoemaker | Myungsup Shin | Patrick Speck | Patricia Stark | Junggi Sung | Hiroaki Tanaka | Martin Topel | Kanaé Tsukamoto | Wolfgang Wagner | Manfred Wang | Jutta Werner | Irmy Wilms-Haferkamp | William (Jian) Wu



DESIGN  
AWARD  
2021

**DISCIPLINE PRODUCT**  
**CATEGORY 1.11 Office**

## Bowi

**innovative horizontal stacking chair**

### DESIGN

brodbeck-koepf design  
Munich, Germany

### CLIENT / MANUFACTURER

Haworth GmbH  
Bad Münden am Deister, Germany

#### Jury

Marika Aakesson | Werner Aisslinger | Josephine Akvama Hoffmeyer | Marta Alonso Yebra | Silvana Angeletti | Keiji Ashizawa | Serdal Korkut Avci | Tomoko Azumi | Jan-Erik Baars | Ceren Bagatar | Stefan Behnisch | Michal Bonikowski | Philipp Bree | Dave Brown | Uwe Brückner | Maïke Budde | Sean Carney | Eva Castro | Annie Chang | Chi-Yi Chang | Emil Chao | Shikuan Chen | Lee Chen | Albert Chen | Patrizio Cionfoli | Paul Cohen | Sonja Cornelißen | Isabelle Dahlborg Lidström | Michele De Lucchi | Christian Doering | Bern Donadeu | Manfred Dorn | Friederike Faller | Fritz Frenkler | Claudia Friedrich | Marisa Gallén | Niklas Galler | Manuel Gattinger | Oliver Gerstheimer | Isabelle Goller | Senna Graulus | Gyeongguk Grey Choe | Matthis Hamann | Sascha Hanke | Gesa Hansen | Sam Hecht | Olivia Herms | Tom Hirt | Britta Hölscher | Daisuke Ishii | Neslihan Isik | Morten Bo Jensen | Henrik Jeppesen | Long Jiao | Ann Kalkschmidt | Karen Korellis Reuther | Henk Kosche | Michael Lanz | Kristiina Lassus | Sukwoo Lee | Lidan Liu | Sam Livingstone | Petra Lundblad | Kazushige Miyake | Nils Holger Moormann | Alexander Müller | Darragh Murphy | Achim Nagel | Stina Nilimaa Wickström | Changho Noh | Katrin Oeding | Lutzia Ortiz Miralles | Haruki Ota | Thomas Paulen | Andy Payne | Achim Pohl | Fátima Pombo | Claudia Pommer | Bruno Porto | Ana Relvão | Nina Rieke | Andreas Rotzler | Robert Sachon | Annett Schaper | Sonja Schiefer | Johanna Schoemaker | Myungsup Shin | Patrick Speck | Patricia Stark | Junggi Sung | Hiroaki Tanaka | Martin Topel | Kanaé Tsukamoto | Wolfgang Wagner | Manfred Wang | Jutta Werner | Irmy Wilms-Haferkamp | William (Jian) Wu